

S700 Series



Applications

Mechanical and electrical interface between on-board military avionics equipments and racks

Standards

MIL C 83527
Pr EN 3682

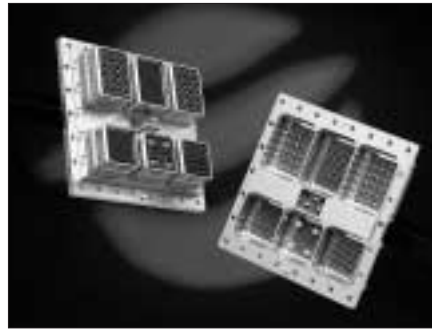

Description

- Rectangular connector
- Three sizes of shells
- A large number of insulators with integral signal, power, coaxial and triaxial contacts
- Shielding bracelet removable without tooling for maximum EMI/RFI protection

Characteristics

Mechanical

- Shell : aluminum alloy
- Finish : cadmium-plating over nickel underplate
- Inserts : thermoset (or aluminum)
- Grommet and seal : elastomer silicone
- Contact : copper alloy
- Contact plating : gold over nickel underplate
- Insert retention plate : blue anodized aluminum alloy
- Screening ring : copper alloy with plating
- Screws : passivate stainless steel
- Mechanical endurance : 500 mating
- Shock : 30 g during 11 ms
- Random vibration : frequency 15 to 2000 Hz

Electrical

- Dielectric withstanding voltage (Vrms)

Contacts sizes	At sea level	Altitude (1.1 k Pa)
# 22	1 300	800
other contacts	1 500	800

- Contacts

Contact sizes	Wire sizes	Current Max in A	Contact resistance mΩ
22	22	5	17
	24	3	23
	26	2	38
20	20	7.5	11
	22	5	17
	24	3	23
16	16	13	6
	18	10	8
	20	7.5	10
12	12	23	3.35
	14	17	4.24

	16 coaxial	12 coaxial	8 triaxial
bandwidth	0-500 MHz	0-1 000 MHz	0-20 MHz
dielectric withstanding voltage	at sea level 800 Vrms 250 Vrms	900 Vrms 250 Vrms	500 Vrms 125 Vrms
voltage drop inner contact	RG179-<120mV/1A RG316-<55mV/1A	RG179-<120mV/1A RG316-<55mV/1A	<15mV/1A
middle contact			<15mV/1A
outer contact	<80mV/12A	<75mV/12A	<35mV/12A

- Shielding effectiveness

Frequency MHz	Attenuation (dB)
100	65
1 000	60

Climatic

- Temperature rating : -65°C +150°C
- Temperature life : 1000 hours at +155°C
- Salt spray : 500 hours
- Fluid resistance : as per MIL-C 83527 test method
MIL-STD 1344 and AECMA EN 2591

Ordering information

Complete connector

basic series	S7 C O P 2 - 001 SO A 01
complete connector	
class	0 - sealed 1 - unsealed 2 - semisealed
shell type	P - rack plug R - equipment receptacle
shell size	2-3-4
contact layout combination	see, insert combination code next page p 173
connector termination style and packaging code	XX - without contact SO - crimp contacts
specification code	A - standard connector (triax # 8 grounded) B - specific connector (triax # 8 not grounded)
polarization	see table p 174

S700 Series



Complete body assembly - without insert

basic series		S7	S	P	2	A	00
shell without insert							
shell type	P - rack plug R - equipment receptacle						
shell size	2-3-4						
obligatory suffix	A - standard connector						
polarization	see table p 174						

Dummy metal insert

basic series		S7T	0	1	0	C
class	0 - sealed 1 - unsealed					
insert size	1 - for cavities A, C, E 2 - for cavities B, D, F					
obligatory suffix						
plating type	C - conductive plating without digit - without conductive plating					

Insert with or without contacts

basic series		S7	T	0	1	P	150
obligatory digit T	- insert											
class	0 - sealed 1 - unsealed 2 - semisealed											
insert size	1 - for cavities A, C, E 2 - for cavities B, D, F											
insert type	P - for rack plug R - for equipment receptacle											
number of monocontacts	see contact layouts p 172											
termination type (monocontact)	without digit - crimp contacts L - without contact											
C...	number of coaxial contacts (to be ordered separately) see contact layouts p 172											
without digit	- without grounding } for insert with coaxial contacts G - with grounding }											
T...	number of triaxial contacts (to be ordered separately) see contact layouts p 172 contacts grounded											
without digit	- without grounding } for insert with triaxial contacts G - with grounding }											

S700 Series



Part number cross reference list Connectors

FCI Souriau part numbers	MIL-C 83527 part numbers	AECMA EN 3682 part numbers
S7C0P2-001S0A01	M83527/01-A001	EN3682P2G00101
S7C0P2-001S0B01		EN3682P2A00101
S7C0P2-001XXA01	M83527/01-B001	EN3682P2G00101L
S7C0P2-001XXB01		EN3682P2A00101L
S7C0R2-001S0A01	M83527/02-A001	EN3682R2G00101
S7C0R2-001S0B01		EN3682R2A00101
S7C0R2-001XXA01	M83527/02-B001	EN3682R2G00101L
S7C0R2-001XXB01		EN3682R2A00101L
S7C0P3-001S0A01	M83527/03-A001	EN3682P3G00101
S7C0P3-001S0B01		EN3682P3A00101
S7C0P3-001XXA01	M83527/03-B001	EN3682P3G00101L
S7C0P3-001XXB01		EN3682P3A00101L
S7C0R3-001S0A01	M83527/04-A001	EN3682R3G00101
S7C0R3-001S0B01		EN3682R3A00101
S7C0R3-001XXA01	M83527/04-B001	EN3682R3G00101L
S7C0R3-001XXB01		EN3682R3A00101L
S7C0P4-001S0A01	M83527/05-A001	EN3682P4G00101
S7C0P4-001S0B01		EN3682P4A00101
S7C0P4-001XXA01	M83527/05-B001	EN3682P4G00101L
S7C0P4-001XXB01		EN3682P4A00101L
S7C0R4-001S0A01	M83527/06-A001	EN3682R4G00101
S7C0R4-001S0B01		EN3682R4A00101
S7C0R4-001XXA01	M83527/06-B001	EN3682R4G00101L
S7C0R4-001XXB01		EN3682R4A00101L

Insulators

FCI Souriau part numbers	MIL-C 83527 part numbers	AECMA EN 3682 part numbers
S7T01P150L	M83527/07-01	EN3682-1P150L
S7T01P150		EN3682-1P150
S7T01R150L	M83527/08-01	EN3682-1R150L
S7T01R150		EN3682-1R150
S7T01P47LT2G	M83527/07-03	EN3682-1P47T2GL
S7T01P47T2G		EN3682-1P47T2G
S7T01P47LT2		EN3682-1P47T2AL
S7T01P47T2		EN3682-1P47T2A
S7T01R47LT2G	M83527/08-03	EN3682-1R47T2GL
S7T01R47T2G		EN3682-1R47T2G
S7T01R47LT2		EN3682-1R47T2AL
S7T01R47T2		EN3682-1R47T2A
S7T01P24L	M83527/07-04	EN3682-1P24L
S7T01P24		EN3682-1P24
S7T01R24L	M83527/08-04	EN3682-1R24L
S7T01R24		EN3682-1R24
S7T01P60L	M83527/07-05	EN3682-1P60L
S7T01P60		EN3682-1P60
S7T01R60L	M83527/08-05	EN3682-1R60L

Insulators

FCI Souriau part numbers	MIL-C 83527 part numbers	AECMA EN 3682 part numbers
S7T01R60		EN3682-1R60
S7T01PC12GT6G		EN3682-1PC2GT6G
S7T01RC12GT6G		EN3682-1RC12GT6G
S7T01P126L		EN3682-1P126L
S7T01P126		EN3682-1P126
S7T01R126L		EN3682-1R126L
S7T01-0		EN3682-1-0
S7T02-0		EN3682-2-0
S7T02P100L	M83527/01-06	EN3682-2P100L
S7T02P100		EN3682-2P100
S7T02R100L	M83527/08-06	EN3682-2R100L
S7T02R100		EN3682-2R100
S7T02P11LC2	M83527/07-07	EN3682-2P11C2L
S7T02P11C2		EN3682-2P11C2
S7T02R11LC2	M83527/08-07	EN3682-2R11C2L
S7T02R11C2		EN3682-2R11C2
S7T02P20LT4G	M83527/07-08	EN3682-2P20T4GL
S7T02P20T4G		EN3682-2P20T4G
S7T02P20LT4		EN3682-2P20T4L
S7T02P20T4		EN3682-2P20T4A
S7T02R20LT4G	M83527/08-08	EN3682-2R20T4GL
S7T02R20T4G		EN3682-2R20T4G
S7T02R20LT4		EN3682-2R20T4L
S7T02R20T4		EN3682-2R20T4A
S7T02P34L	M83527/07-09	EN3682-2P34L
S7T02P34		EN3682-2P34
S7T02R34L	M83527/08-09	EN3682-2R34L
S7T02R34		EN3682-2R34
S7T02PT6G	M83527/07-10	EN3682-2PT6G
S7T02RT6G	M83527/08-10	EN3682-2RT6G
S7T02P62LT2G		EN3682-2P62T2GL
S7T02P62T2G		EN3682-2P62T2G
S7T02P62LT2		EN3682-2P62T2AL
S7T02P62T2		EN3682-2P62T2A
S7T02R62LT2G		EN3682-2R62T2GL
S7T02R62T2G		EN3682-2R62T2G
S7T02R62LT2		EN3682-2R62T2AL
S7T02R62T2		EN3682-2R62T2A
S7T02P11LT2G		EN3682-2P11T2GL
S7T02P11T2G		EN3682-2P11T2G
S7T02P11LT2		EN3682-2P11T2AL
S7T02P11T2		EN3682-2P11T2A
S7T02R11LT2G		EN3682-2R11T2GL
S7T02R11T2G		EN3682-2R11T2G
S7T02R11LT2		EN3682-2R11T2AL
S7T02R11T2		EN3682-2R11T2A

S700 Series



Contact layouts Viewed from front face of male insulator

Cavities - A, C, E

ARRANGEMENTS number of contacts	1-150 150 size 22	1-126 120 size 22 6 size 16	1-60 60 size 20	1-47T2 47 size 20 2 triaxial size 8
ARRANGEMENTS number of contacts	1-24 24 size 12	1-C1 2T6 12 coaxial size 12 6 triaxial size 8	1-0 dummy metal insert	

Cavities - B, D, F

ARRANGEMENTS number of contacts	2-100 100 size 22	2-62T2 60 size 22 2 size 16 2 triaxial 8	2-34 24 size 20 10 size 16	2-20T4 20 size 20 4 triaxial size 8
ARRANGEMENT number of contacts	2-11C2 4 size 20 3 size 16 4 size 12 2 coaxial size 5	2-11T2 4 size 20 3 size 16 4 size 12 2 triaxial size 8	2-T6 6 triaxial size 8 metal insert	2-0 dummy metal insert

S700 Series



Insert combination code

code	shell size	insert combination in shell			
		A	B	C	D
001	2	1 - 47T2	2 - 100		
002	2	1 - 47T2	2 - 20T4		
003	2	1 - 47T2	2 - 34		
200	2	empty	empty		
201	2	1 - 150	2 - 34		
203	2	1 - 126	2 - 100		
204	2	1 - 150	2 - 11C2		
207	2	1 - 150	2 - 20T4		
209	2	1 - 47T2	2 - 11C2		
211	2	1 - 150	2 - 11T2		
212	2	1 - 60	2 - 11T2		
216	2	1 - 150	2 - 100		
217	2	1 - 24	2 - 11C2		
224	2	1 - 150	2 - 62T2		
225	2	1 - 60	2 - 20T4		
230	2	1 - 47T2	2 - 0		
231	2	1 - 24	2 - 0		
232	2	1 - 24	2 - 34		
237	2	1 - 24	2 - 100		
256	2	1 - 60	2 - 11C2		
263	2	1 - 60	2 - T6G		

code	shell size	insert combination in shell					
		A	B	C	D	E	F
229	3	1 - 150	2 - 20T4	1 - 24	2 - 11C2		
233	3	1 - 150	2 - 34	1 - 150	2 - 34		
234	3	1 - 24	2 - 11C2	1 - 150	2 - 100		
235	3	1 - 150	2 - 0	1 - 150	2 - 20T4		
238	3	1 - 0	2 - 11C2	1 - 0	2 - 20T4		
239	3	1 - 24	2 - 34	1 - 24	2 - 34		
240	3	1 - 47T2	2 - 34	1 - 24	2 - 34		
242	3	1 - 0	2 - 11C2	1 - 0	2 - 34		
243	3	1 - 60	2 - 34	1 - 24	2 - 34		
245	3	1 - 150	2 - 11C2	1 - 24	2 - 11C2		
250	3	1 - 24	2 - 0	1 - 150	2 - 20T4		
251	3	1 - 126	2 - 34	1 - 126	2 - 20T4		
252	3	1 - 150	2 - 34	1 - 0	2 - 11C2		
253	3	1 - 24	2 - 100	1 - 150	2 - 20T4		
254	3	1 - 150	2 - 62T2	1 - 150	2 - 62T2		
255	3	1 - 150	2 - 11C2	1 - 0	2 - 34		
257	3	1 - 150	2 - 100	1 - C12T6	2 - 34		
258	3	1 - 150	2 - 11C2	1 - 150	2 - 34		
260	3	1 - 150	2 - T6	1 - 150	2 - 34		
261	3	1 - 150	2 - 11C2	1 - 126	2 - 34		
262	3	1 - 150	2 - 100	1 - 150	2 - 62T2		
270	3	1 - 150	2 - 11T2	1 - 150	2 - 20T4		
271	3	1 - 150	2 - 11T2	1 - 150	2 - 11T2		

code	shell size	insert combination in shell			
		A	B	C	D
004	3	1 - 150	2 - 34	1 - 150	2 - 20T4
005	3	1 - 150	2 - 100	1 - 47T2	2 - 100
006	3	1 - 60	2 - 100	1 - 60	2 - 100
007	3	1 - 150	2 - 100	1 - 150	2 - 100
008	3	1 - 60	2 - 34	1 - 60	2 - 34
200	3	empty	empty	empty	empty
202	3	1 - 150	2 - 20T4	1 - 0	2 - 100
205	3	1 - 150	2 - T6	1 - 150	2 - T6
208	3	1 - 150	2 - 20T4	1 - 150	2 - 0
210	3	1 - 150	2 - 11C2	1 - 24	2 - 100
213	3	1 - 24	2 - 34	1 - 24	2 - 20T4
214	3	1 - 24	2 - 34	1 - 0	2 - 20T4
215	3	1 - 150	2 - 100	1 - C12T6	2 - 11C2
218	3	1 - 24	2 - 11C2	1 - 24	2 - T6G
222	3	1 - 150	2 - 11T2	1 - 24	2 - 100
223	3	1 - 150	2 - 11C2	1 - 150	2 - 11C2
226	3	1 - 150	2 - 34	1 - 150	2 - 100
227	3	1 - 150	2 - 20T4	1 - 24	2 - 0
228	3	1 - 150	2 - 100	1 - 150	2 - 20T4

code	shell size	insert combination in shell					
		A	B	C	D	E	F
009	4	1 - 150	2 - 34	1 - 150	2 - 20T4	1 - 150	2 - 20T4
010	4	1 - 24	2 - 34	1 - 150	2 - 100	1 - 150	2 - 20T4
011	4	1 - 150	2 - 34	1 - 150	2 - 20T4	1 - 150	2 - T6
012	4	1 - 24	2 - 34	1 - 150	2 - 0	1 - 150	2 - 20T4
200	4	empty	empty	empty	empty	empty	empty
219	4	1 - 24	2 - 11C2	1 - 47T4	2 - 34	1 - 24	2 - 20T4
220	4	1 - 150	2 - 100	1 - 150	2 - 100	1 - 150	2 - 100
221	4	1 - 24	2 - 34	1 - 150	2 - 20T4	1 - 150	2 - T6
236	4	1 - 24	2 - 34	1 - 24	2 - 0	1 - 150	2 - 20T4
241	4	1 - 24	2 - 34	1 - 24	2 - 34	1 - 24	2 - 34
244	4	1 - 60	2 - 34	1 - 60	2 - 34	1 - 24	2 - 34
246	4	1 - 24	2 - 34	1 - 60	2 - 100	1 - 150	2 - 20T4
247	4	1 - 24	2 - 34	1 - 24	2 - 100	1 - 150	2 - 20T4
248	4	1 - 60	2 - T6	1 - 60	2 - T6	1 - 24	2 - T6
249	4	1 - 60	2 - T6	1 - 0	2 - T6	1 - 150	2 - T6
259	4	1 - 150	2 - 20T4	1 - 24	2 - T6G	1 - 150	2 - 11T2
272	4	1 - 150	2 - 34	1 - 150	2 - 100	1 - 150	2 - 20T4

S700 Series



Polarization Rack plug

00 - polarizing key delivered unmounted

position	L.H. key	centre key	R.H.key
01	1	1	1
02	2	1	1
03	3	1	1
04	4	1	1
05	5	1	1
06	6	1	1
07	1	1	6
08	2	1	6
09	3	1	6
10	4	1	6
11	5	1	6
12	6	1	6
13	1	1	5
14	2	1	5
15	3	1	5
16	4	1	5
17	5	1	5
18	6	1	5
19	1	1	4
20	2	1	4
21	3	1	4
22	4	1	4
23	5	1	4
24	6	1	4
25	1	1	3
26	2	1	3
27	3	1	3
28	4	1	3
29	5	1	3
30	6	1	3
31	1	1	2
32	2	1	2
33	3	1	2
34	4	1	2
35	5	1	2
36	6	1	2
37	1	2	1
38	2	2	1
39	3	2	1
40	4	2	1
41	5	2	1
42	6	2	1
43	1	2	6
44	2	2	6
45	3	2	6
46	4	2	6
47	5	2	6
48	6	2	6
49	1	2	5
50	2	2	5
51	3	2	5
52	4	2	5
53	5	2	5
54	6	2	5
55	1	2	4
56	2	2	4
57	3	2	4
58	4	2	4
59	5	2	4
60	6	2	4
61	1	2	3
62	2	2	3
63	3	2	3
64	4	2	3
65	5	2	3
66	6	2	3
67	1	2	2
68	2	2	2
69	3	2	2
70	4	2	2
71	5	2	2
72	6	2	2
73	1	3	1
74	2	3	1
75	3	3	1
76	4	3	1
77	5	3	1
78	6	3	1
79	1	3	6
80	2	3	6
81	3	3	6
82	4	3	6
83	5	3	6
84	6	3	6
85	1	3	5
86	2	3	5
87	3	3	5
88	4	3	5
89	5	3	5
90	6	3	5
91	1	3	4
92	2	3	4
93	3	3	4
94	4	3	4
95	5	3	4
96	6	3	4
97	1	3	4
98	2	3	3
99	3	3	3

Equipment receptacle

00 - polarizing eyes delivered unmounted

position	L.H. key	centre key	R.H.key
01	4	4	4
02	4	4	3
03	4	4	2
04	4	4	1
05	4	4	6
06	4	4	5
07	5	4	4
08	5	4	3
09	5	4	2
10	5	4	1
11	5	4	6
12	5	4	5
13	6	4	4
14	6	4	3
15	6	4	2
16	6	4	1
17	6	4	6
18	6	4	5
19	1	4	4
20	1	4	3
21	1	4	2
22	1	4	1
23	1	4	6
24	1	4	5
25	2	4	4
26	2	4	3
27	2	4	2
28	2	4	1
29	2	4	6
30	2	4	5
31	3	4	4
32	3	4	3
33	3	4	2
34	3	4	1
35	3	4	6
36	3	4	5
37	4	3	4
38	4	3	3
39	4	3	2
40	4	3	1
41	4	3	6
42	4	3	5
43	5	3	4
44	5	3	3
45	5	3	2
46	5	3	1
47	5	3	6
48	5	3	5
49	6	3	4
50	6	3	3
51	6	3	2
52	6	3	1
53	6	3	6
54	6	3	5
55	1	3	4
56	1	3	3
57	1	3	2
58	1	3	1
59	1	3	6
60	1	3	5
61	2	3	4
62	2	3	3
63	2	3	2
64	2	3	1
65	2	3	6
66	2	3	5
67	3	3	4
68	3	3	3
69	3	3	2
70	3	3	1
71	3	3	6
72	3	3	5
73	4	3	4
74	4	3	3
75	4	3	2
76	4	3	1
77	4	3	6
78	4	3	5
79	5	3	4
80	5	3	3
81	5	3	2
82	5	3	1
83	5	3	6
84	5	3	5
85	6	3	4
86	6	3	3
87	6	3	2
88	6	3	1
89	6	3	6
90	6	3	5
91	1	2	4
92	1	2	3
93	1	2	2
94	1	2	1
95	1	2	6
96	1	2	5
97	2	2	4
98	2	2	3
99	2	2	2

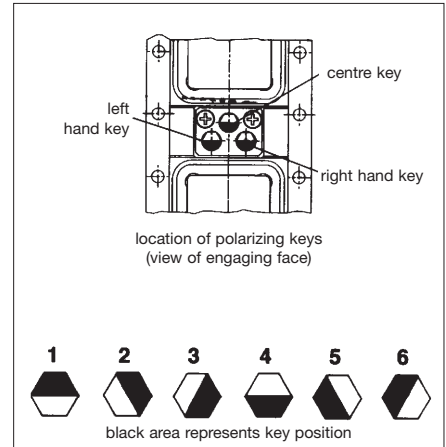

Polarizing post - rack plug

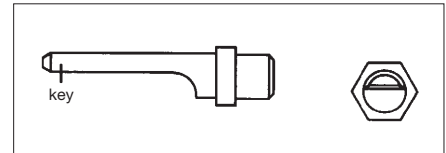

Polarizing post - equipment receptacle

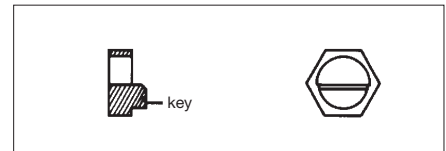

ATTENTION :

00 - unmounted keys part number
(supplied separately)

01 - standard order, part number,
for other location indicate the
number in suffix

Example :

Connector marking :
S7C0P2-001S0A23 (location 23)

S700 Series



Dimensions (mm)

New type of removable RFI bracelet without tool
Shell size 2

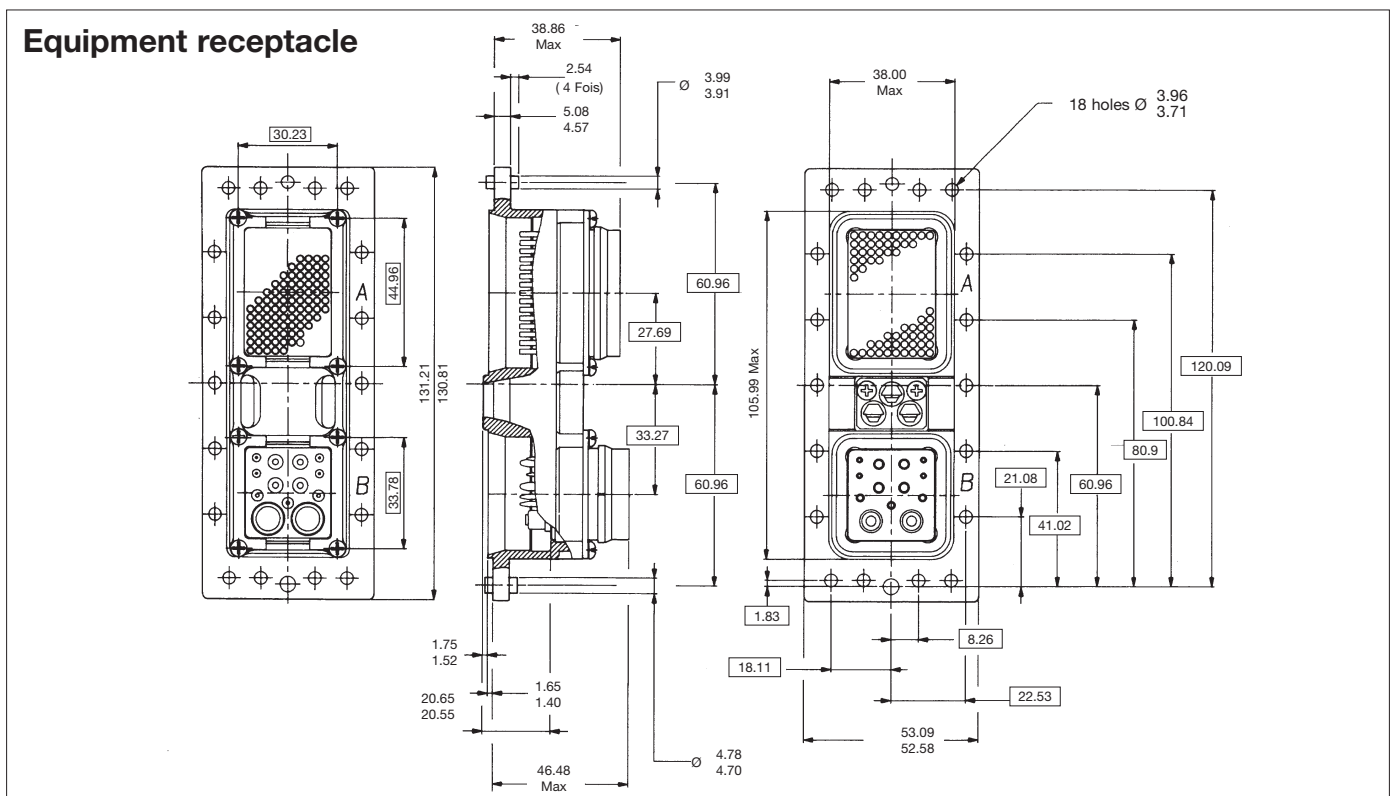
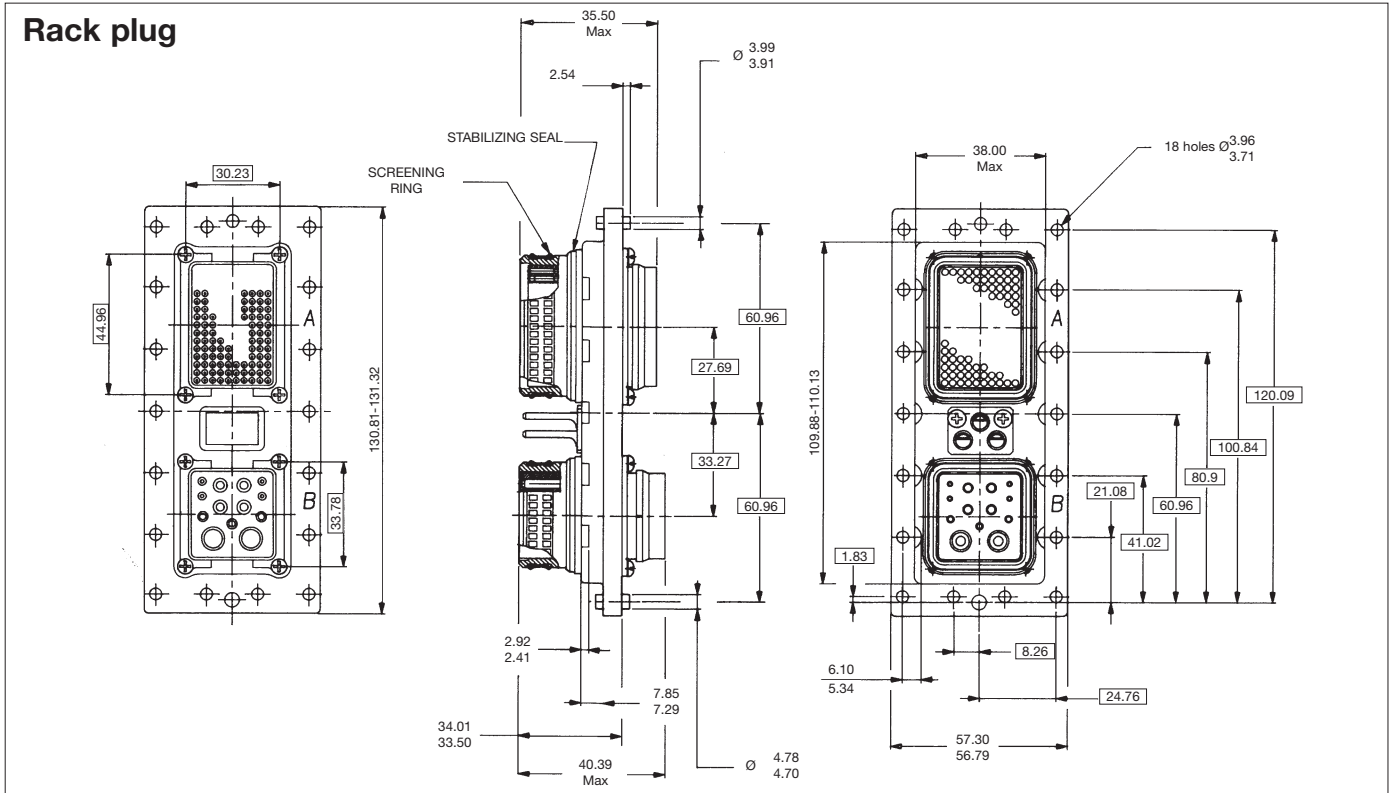

S700 Series



New type of removable RFI bracelet without tool Shell size 3

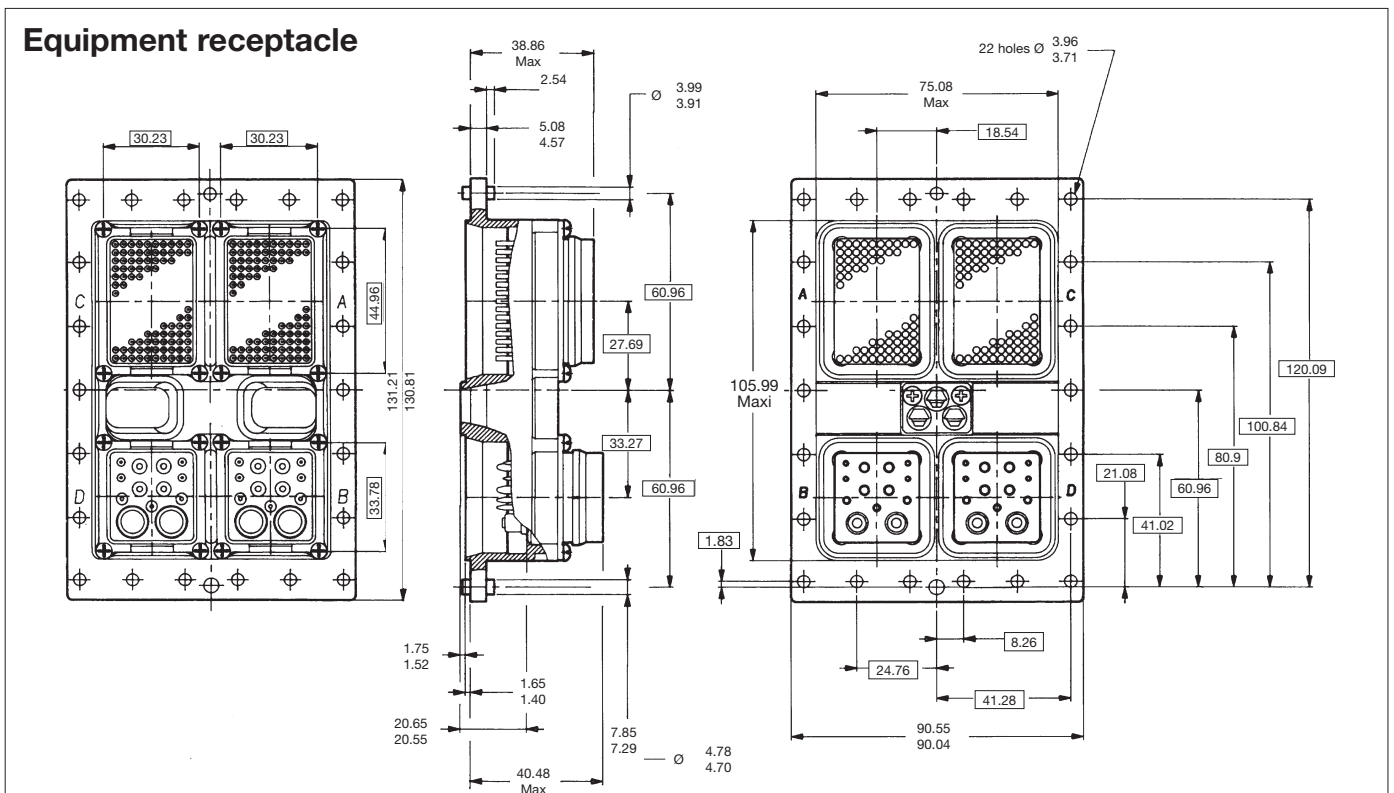
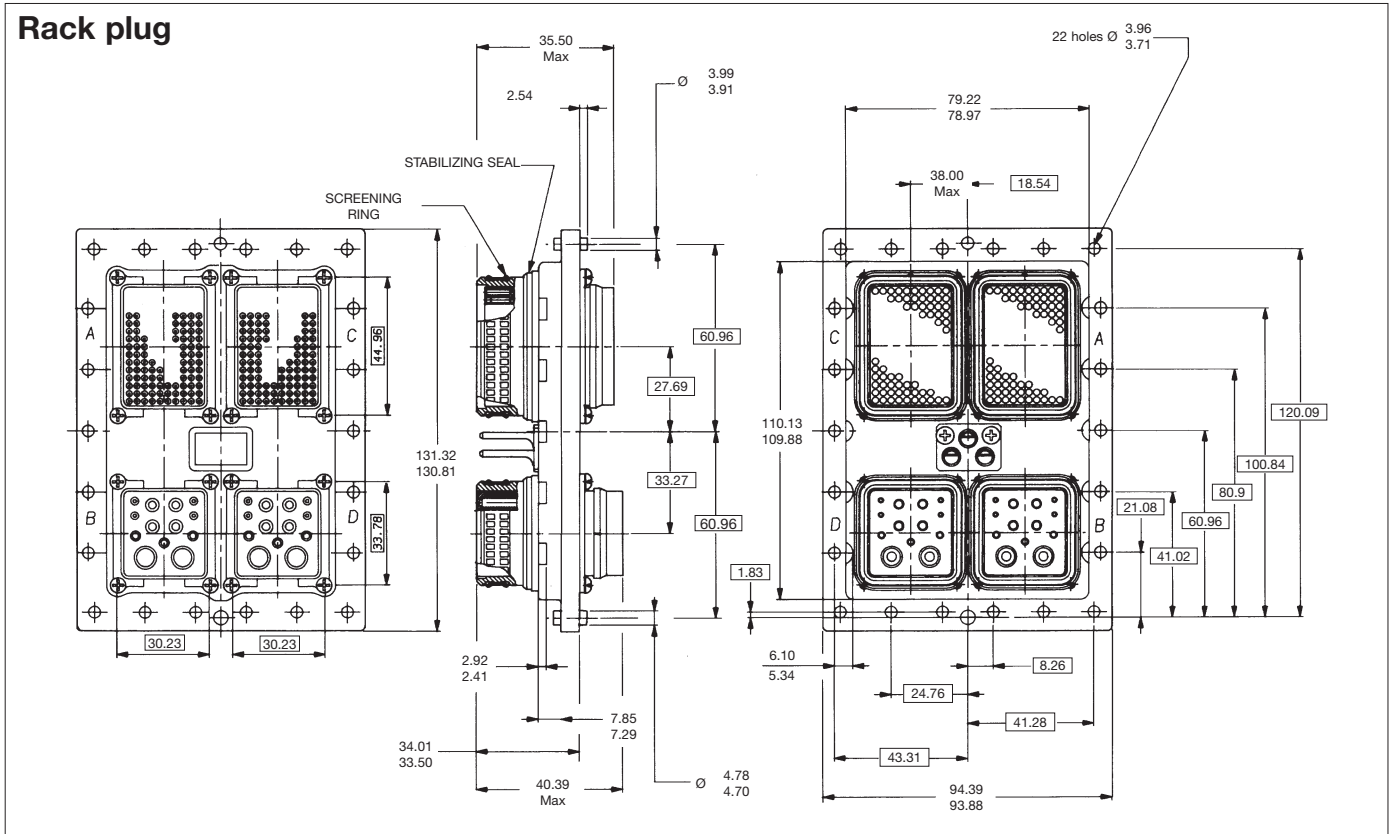

S700 Series



New type of removable RFI bracelet without tool Shell size 4

Rack plug

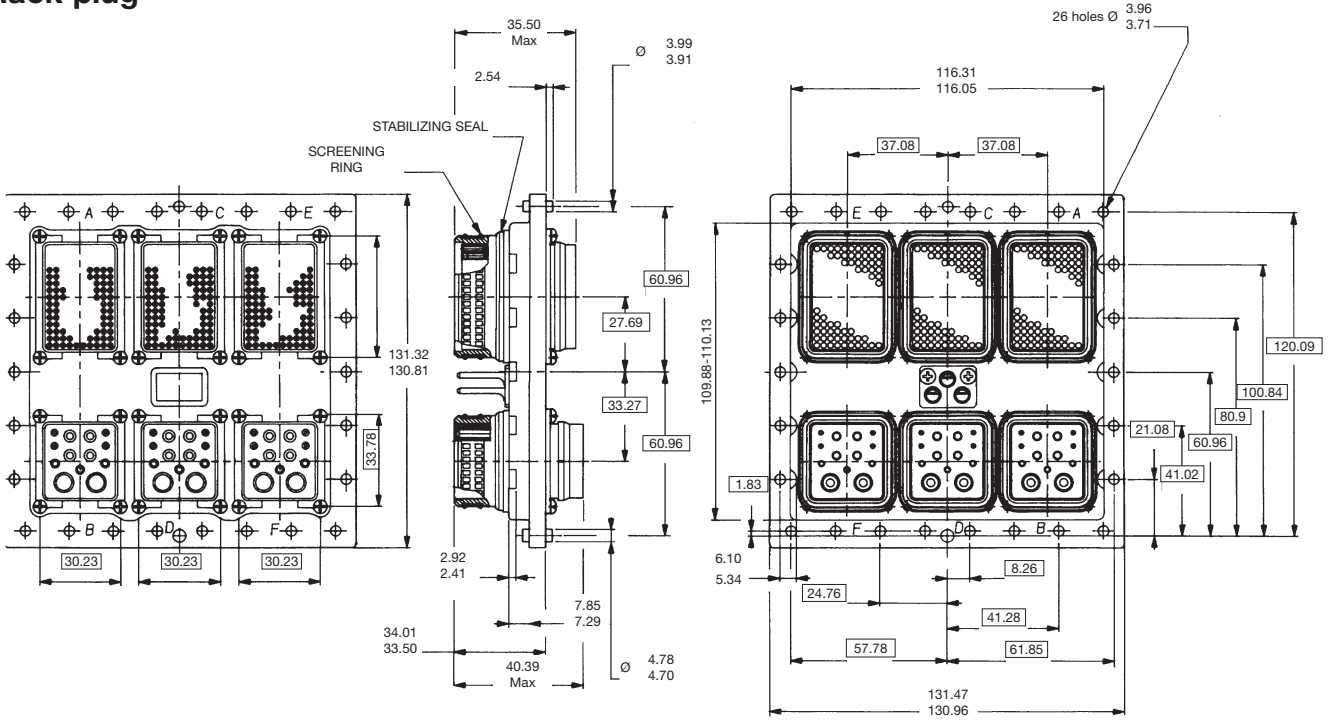

Equipment receptacle

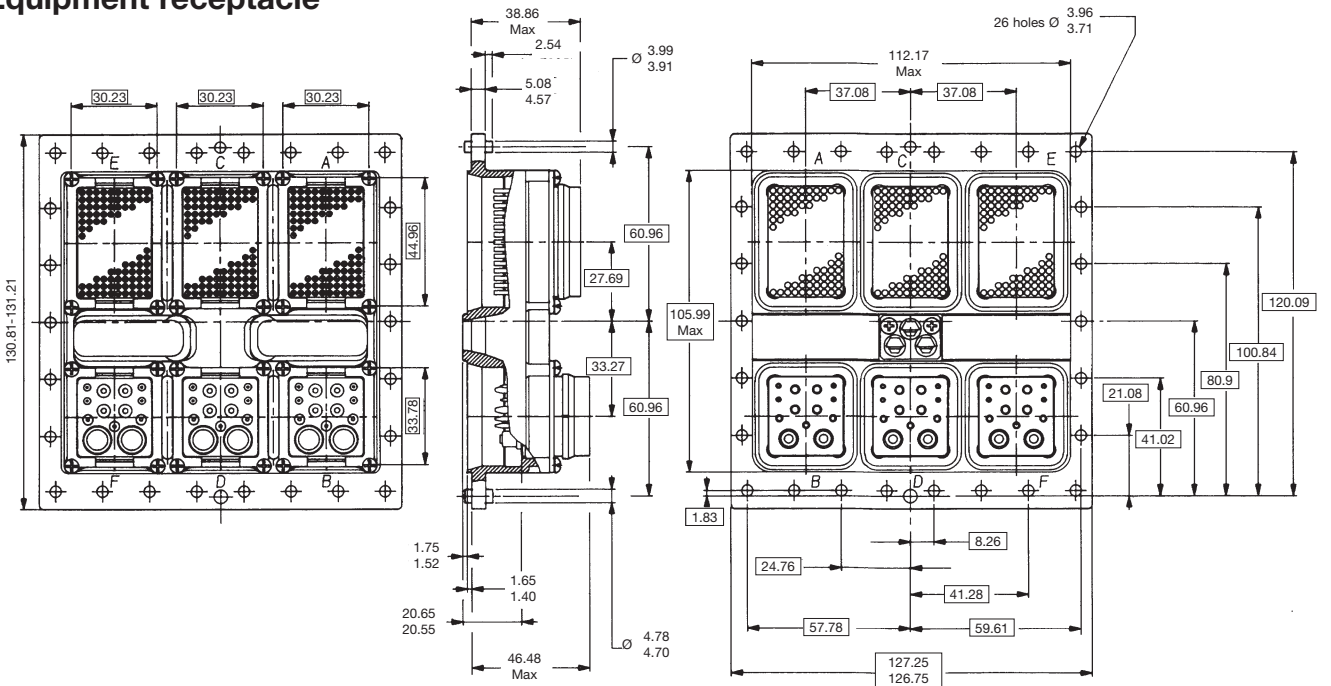

S700 Series



Panel cut out

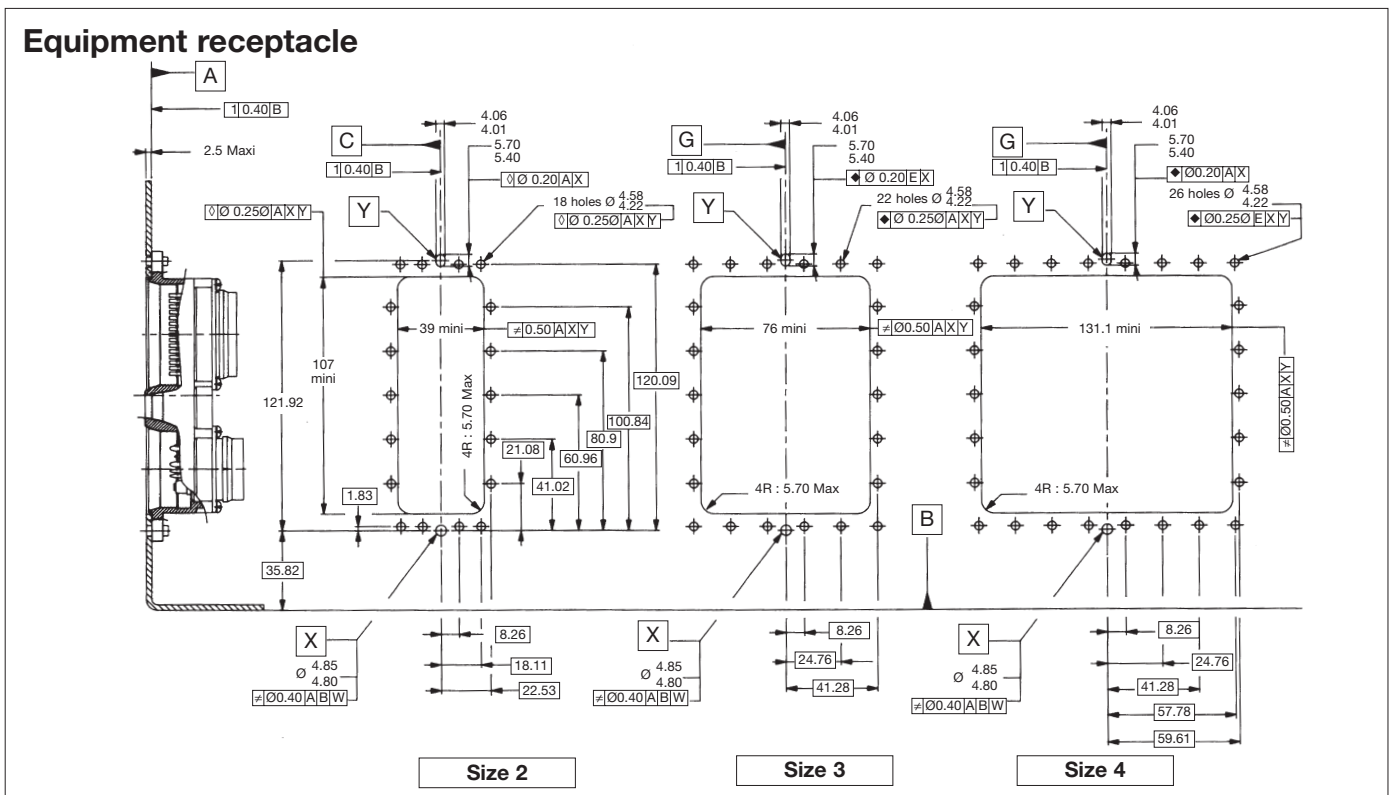
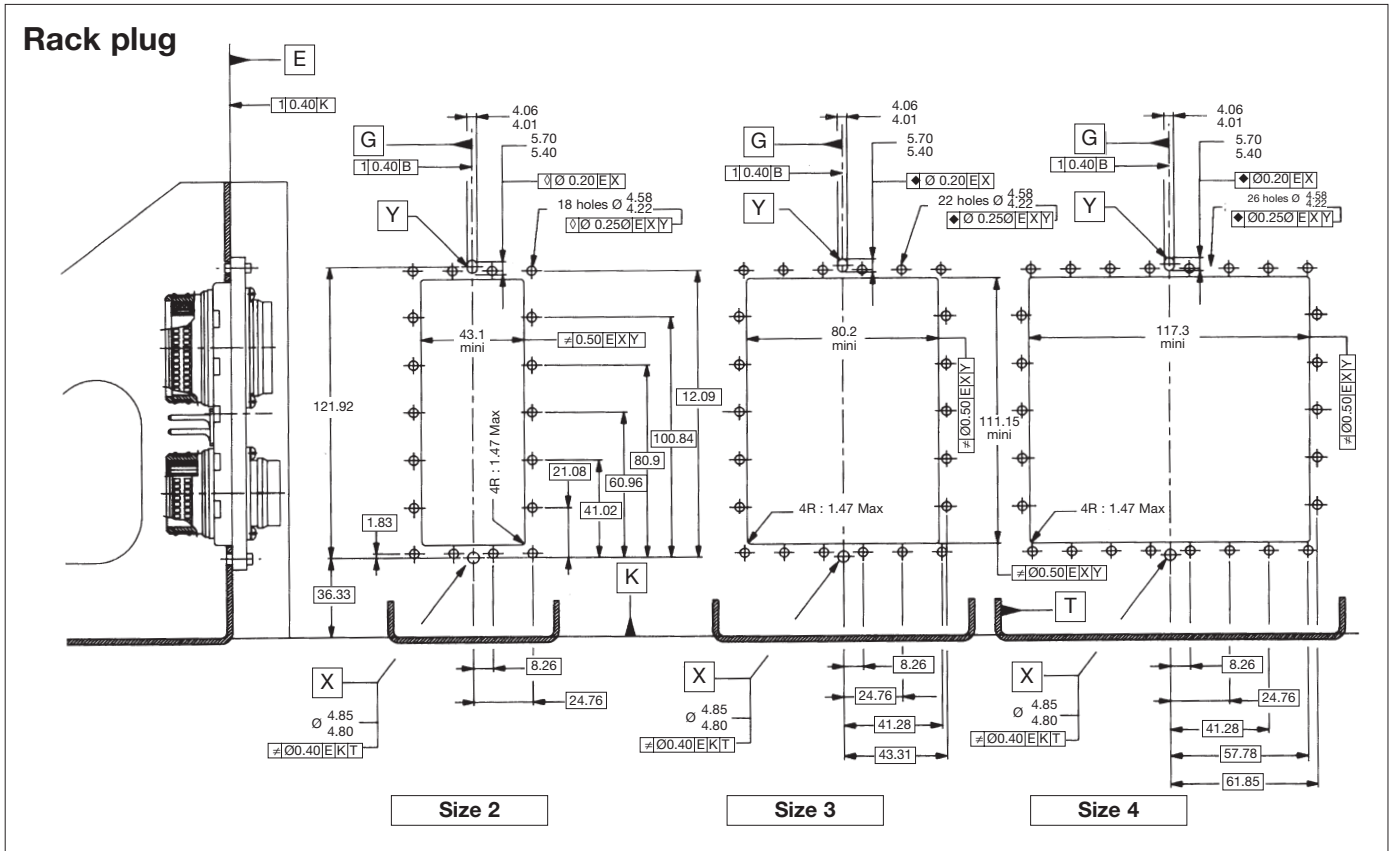

S700 Series



Contacts

Equipment receptacle

Contacts size 22, 20, 16, 12

contacts sizes	part numbers	
22	8667-C03-22R-01A/01	blue black brown
20	8667-C01-20R-01A/01	green white grey
16	8667-C01-16R-01A/01	green orange white
12	8667-C01-12R-01A/01	green yellow black

Rack plug

contacts sizes	part numbers	
22	8667-C01-22R-01A/01	green white violet
20	8667-C03-20R-01A/01	red blue black
16	8667-C03-16R-01A/01	orange blue black
12	8667-C03-12R-01A/01	yellow blue black

Coaxial contacts size 16 for RG 179 B/U, RG 316 B/U and KX 22 DT cables

16	8667-D02-16R-01A/01	
----	---------------------	--

16	8667-D03-16R-01A/01	
----	---------------------	--

Coaxial contacts size 16 for AXON 2619 CE 60/50 DT and 3007 CR 40/75 DT cables

16	8667-D02-16R-02A/01	
----	---------------------	--

16	8667-D03-16R-02A/01	
----	---------------------	--

Coaxial contacts size 12 for cable KX 21 DT

12	8667-D02-12R-02A/01	
----	---------------------	--

12	8667-D03-12R-02A/01	
----	---------------------	--

Coaxial contacts size 12 for RG 179 B/U, RG 316 B/U and KX 22 DT cables

12	8667-D02-12R-01A/01	
----	---------------------	--

12	8667-D03-12R-01A/01	
----	---------------------	--

Coaxial contacts size 5 for RG 58, RG 141 and KX 15 cables

unsealed	8667-D02-05R-01A/01	green yellow white
sealed	8667-D02-05R-51A/01	green yellow white

unsealed	8667-D03-05R-01A/01	black green green
sealed	8667-D03-05R-51A/01	black green green

S700 Series



Equipment receptacle

Size 8 triaxial for cables MIL-C 17176 00002 - EN 3374-003 - NFL 52161-1

unsealed	8667-D02-08R-01A/01	
sealed	8667-D02-08R-51A/01	

Rack plug

unsealed	8667-D03-08R-01A/01	
sealed	8667-D03-08R-51A/01	

Size 8 triaxial for cables NFL 52161-2 - NFL 52161-3 - EN 3374-004

unsealed	8667-D02-08R-02A/01	
sealed	8667-D02-08R-52A/01	

unsealed	8667-D03-08R-02A/01	
sealed	8667-D03-08R-52A/01	

Thermocouples contacts # 22

chromel	8667-C03-220-02A/01	yellow code	
alumel	8667-C03-220-03A/01	black code	

chromel	8667-C01-220-02A/01	yellow code	
alumel	8667-C01-220-03A/01	black code	

Cavities reducers # 8 → # 12 consult the factory

Straight spill contacts for equipment receptacle

contacts type	contacts sizes	part numbers	dimensions (mm)			
			A	L	Ø	
female	22	8667-C23-22R-01A/01	13.98	3.80	0.63	
		8667-C23-220-02A/04	16.35	3.80	0.63	
		8667-C23-220-03A/04	16.35	10.00	0.63	
male	20	8667-420-200-01A/MJ	10.10	3.80	0.63	
	16	8667-420-160-01A/MJ	10.55	3.80	0.63	
	12	8667-420-120-01A/MJ	10.55	3.80	0.63	

S700 Series



Contact arrangements in shells

	P : rack plug	R : equipment receptacle
contacts size 22	male	female
contacts size 20, 16, 12	female	male
coaxial contacts size 16, 12, 5 and triaxial contacts size 8	female	male

Wire data for crimp contacts

contacts sizes	contacts Ø	Admissible wire section				External Ø over insulation	
		AWG		mm ²		mm	
		min	Max	min	Max	min	Max
22	0.76	26	22	0.14	0.38	0.66	1.37
20	1	24	20	0.21	0.60	0.82	1.80
16	1.6	20	16	0.60	1.34	1.34	2.62
12	2.4	14	12	1.91	3.18	1.90	3.43
16 coaxial		RG 179 B/U - RG 316 B/U - KX 22 DT AXON 2619 CE 60/50 DT AXON 3007 CR 40/75 DT				1.34	2.62
12 coaxial		RG 179 / KX 22 DT RG 316 / KX 21 DT				2.67 2.59	
5 coaxial		RG 58 - KX 15 - RG 141				4.95 4.84	
8 triaxial		MIL-C-17-176 00002 EN 3374-003 - NFL 52161-1 NFL 52161-2 - EN 3374-004 EN 3374-005 -NFL 52161-3					

Filler plug (sealed version)

cavities size	filler plug part numbers	colour
22	8660-212	black
20	8522-389A	red
16	8522-390A	blue
12	8522-391A	yellow
5	8660-726	white
8	8660-3035	red

Dummy contacts

cavities size	dummy contacts part numbers	
	plug	receptacle
22	8667-6A0-220-02A/AA	8667-6A0-220-01A/AA
20	8667-6A0-200-01A/AA	
16	8667-6A0-160-01A/AA	
12	8667-6A0-120-01A/AA	
5	8667-6A0-050-02A/AA	8667-6A0-050-01A/AA
8	8667-6A0-080-01A/AA	

S700 Series



Shielding cover (mm dimensions) For cavities A, C and E

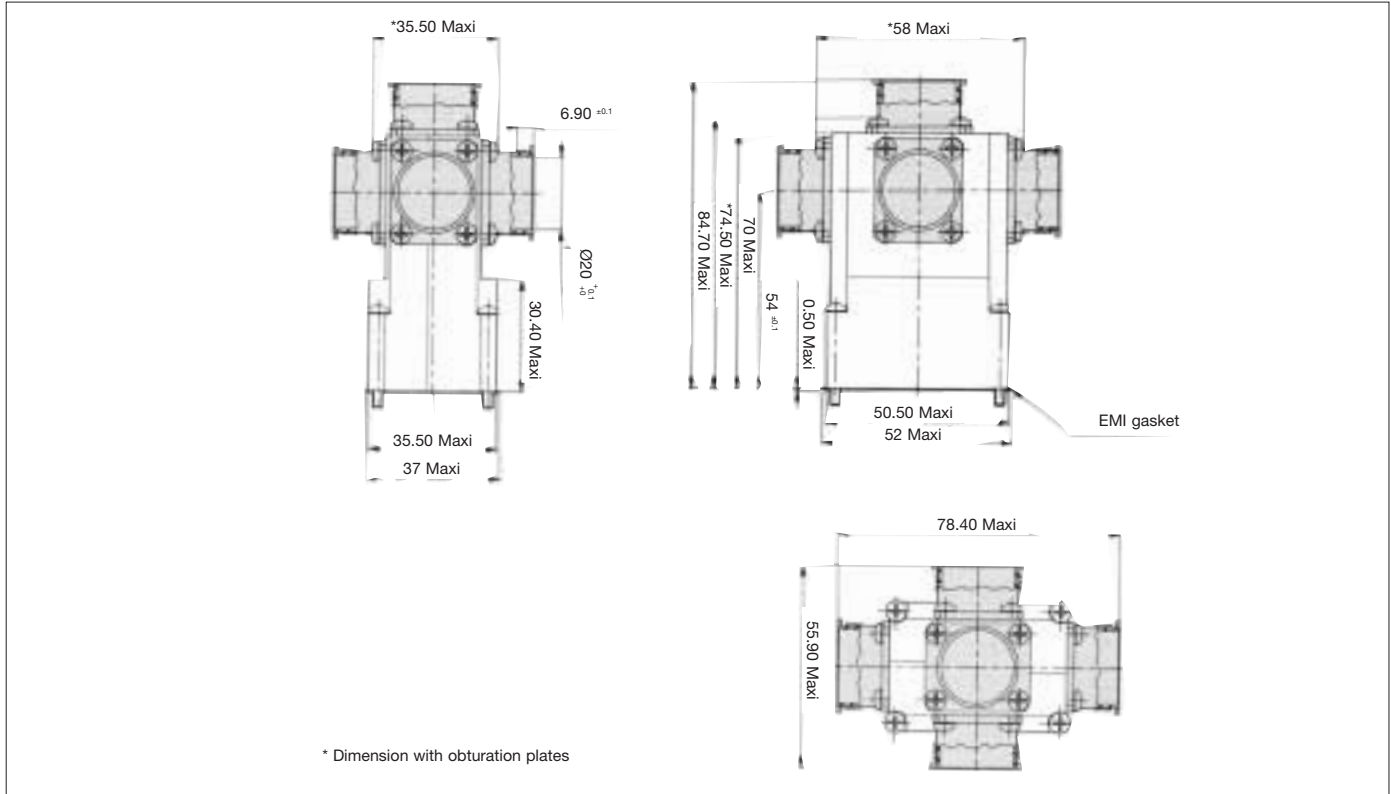

For cavities B, D and F

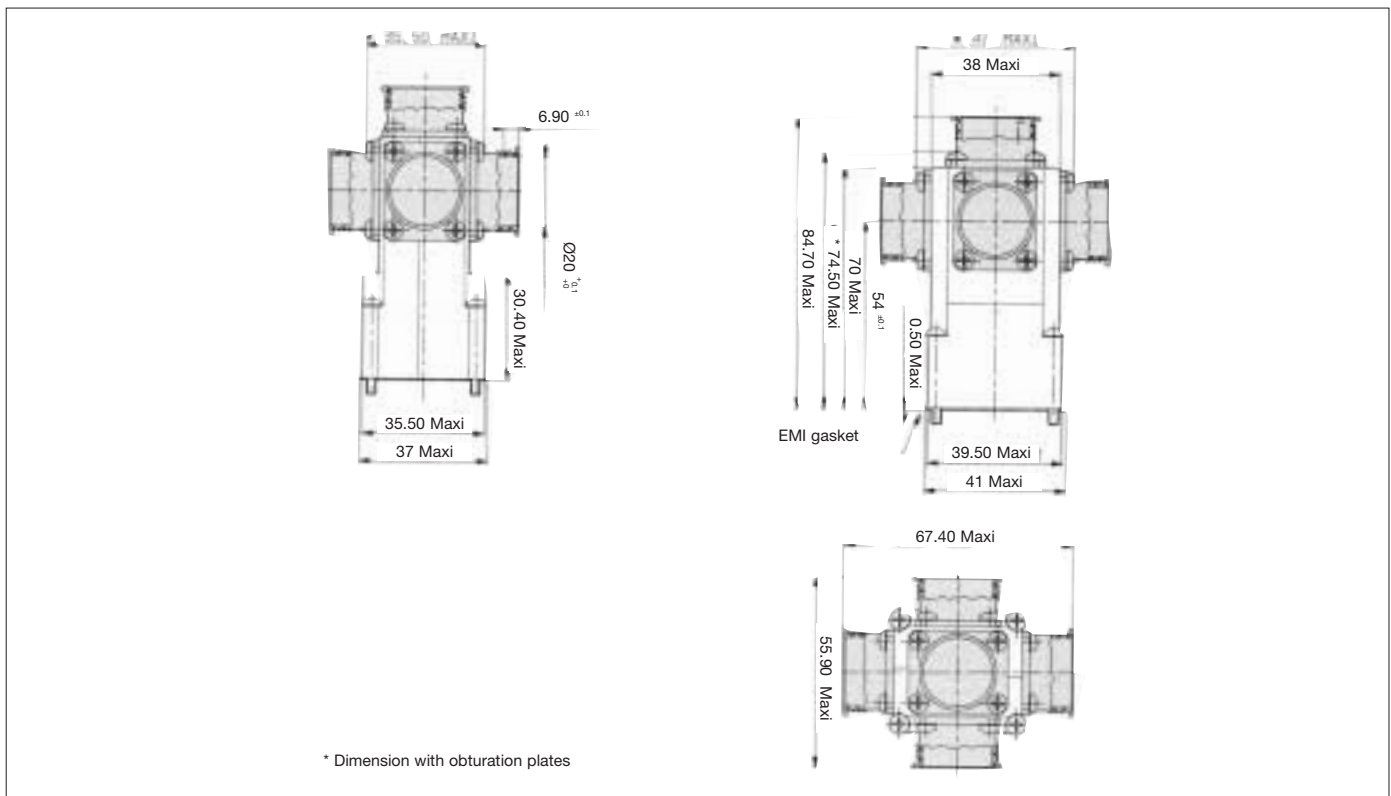

S700 Series



Receptacle with straight spill contact

female straight spill contact size 22 (rear release)		
L	A	part number
31.65	3.80	8667-C23-22R-01A/01
34	3.80	8667-C23-220-02A/04
34	10	8667-C23-220-03A/04

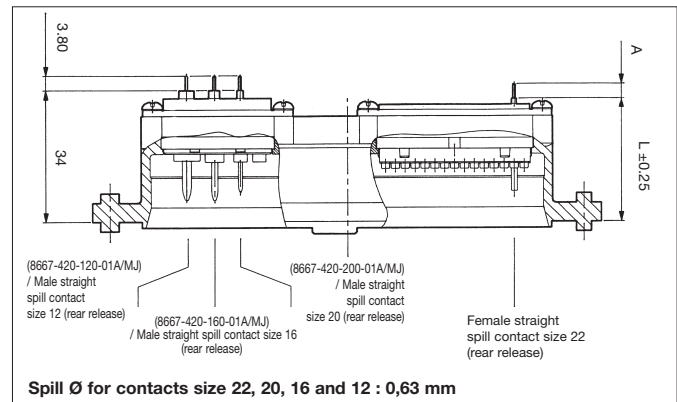

Tooling

Crimping (contacts sizes 22, 20, 16 and 12)

contact sizes	cables		part numbers	
	AWG	section in mm2	crimping tool	locator
22	22	0.38	8476-01 (M22520/2-01)	8660-216 (M22520/2-23)
	24	0.21		
	26	0.15		
20	20	0.60	8476-01 (M22520/2-01)	8476-08 (M22520/2-08)
	22	0.38		
	24	0.21		
16	20	0.60	8365 (M22520/1-01)	8365-02 (M22520/1-02)
	18	0.93		
	16	1.34		
12	14	1.91	8365 (M22520/1-01)	8365-02 (M22520/1-02)
	12	3.18		

Crimping (coaxial contacts)

contact sizes	cables	inner contact		body (ferrule)	
		crimping plier	locator	crimping plier	hex dies
16	RG 179 B/U - RG 316 B/U AXON 2619 CE 60/50 DT AXON 3007 CR 40/75 DT KX 22 DT	8476-01 (M22520/1-01)		M22520/4-01	
12	RG 179 B/U - RG 316 B/U KX 22 DT - KX 21 DT	8476-01 (M22520/2-01)	SN 2176 K100	M22520/31-01	SN 2176 K101
5	RG 58 B/U - RG 141 B/U - KX 15	8476-01 (M22520/2-01)	M22520/2-14	M22520/5-01	M22520/5-45B

Crimping (size 8 triaxial contacts)

contact size	inner contact		intermediary contact		body	
	crimping tool	locator	crimping tool	locator	crimping tool	hex dies
8	8476-1 (M22520/2-01)	8476-37 (M22520/2-37)	8476-01 (M22520/2-01)	SN 1767 K100	M22520/5-01	M22520/5-45B

Contact insertion and extraction

Contact sizes	Tools part numbers / insertion and extraction	colour
22	M81969/ 1-01	green
20	8660-18 (M81969/1-02)	red
16	M81969/14-03	blue
12	M81969/14-04	yellow
16 coaxial	-	-
12 coaxial	M81969/14-04	yellow
5 coaxial	Insertion : manual	-
	Extraction : 8660-187 (M81969/28-01)	yellow
8 triaxial	Insertion : manual	
	8660-197	steel