



In the frame of Space Station Alpha program, SOURIAU has developed and qualified a series of Quick Disconnect high reliability circular connector for robotic operations. This hardware is used as ORU interface on the JEM (Japanese Experiment Module Exposed) Facility which is part of the Japanese contribution to the Space Station. These connectors feature :

- Low Insertion Force contacts
- Thermal gradient compatibility
- Integrated misalignment catching system
- High durability (6000 operations)
- High EMI shielding efficiency
- Deep space environment (Atox) compatibility
- Arrangements from MIL-DTL-38999.



## Performances

### Mechanical and electrical

Mechanical
<b>Mass</b> <ul style="list-style-type: none"> <li>• &lt; 180 g for ORU plug</li> <li>• &lt; 95 g for receptacle</li> </ul>
<b>ORU plug misalignments</b> <ul style="list-style-type: none"> <li>• <math>D_a = \pm 0,9^\circ</math> (movement around the X axis)</li> <li>• <math>D_b = \pm 0,9^\circ</math> (angle authorized between the panels)</li> <li>• <math>r = 1,95</math> mm (plane movement according to Y and Z requirements)</li> </ul>
<b>ORU receptacle overstroke</b> <ul style="list-style-type: none"> <li>• <math>D_X \geq 1,5</math> mm</li> </ul>

Electrical
Contact resistance as per MIL-DTL 39029

### Materials and finishes

	Components	Material	Finish
<b>Connector</b>	Shells (receptacle & plug)	Aluminium alloy 7075	Nickel plating
	Inserts - Insulator	Epichlorhydrile + Polyal + Glass fiber or Polyetherimide resin	-
	- Grommet	Silicone	-
	Contacts	see contacts L.I.F.	see contacts L.I.F.
	Contact retaining clip	Copper alloy	-
<b>LSD (*)</b>	Receptacle & plug bottom plate and mechanical parts	Aluminium alloy 7075	Nickel plating
	Springs	Stainless steel	-

(1) LSD : Lauching Security Device

### Mating/Demating forces

	Mating force (N) (2)	Demating force (N)
<b>25L-3</b>	62	52
<b>25L-7</b>	84	63
<b>25-19</b>	125	102
<b>25-20</b> (1)	161	158
<b>25-35</b>	142	116
<b>25-61</b>	110	84

(1) Configuration 3 # 16 optical contacts + 3 # 16 electrical contacts

(2) At room condition before compliance mechanism acting.

## Circular Robotic Connectors



## Part Number / Characteristics

SOURIAU Part number	Type	Mass in gram (with contacts)	Insert	Layouts		Male insert (in front view)
				Qty	Type	
8977-09A	Plug	178	25L-3	1	# 8 (pc)	
8977-10A	Receptacle	92		2	# 4 (pc)	
8977-11A	Plug	187	25L-7	7	# 8 (pc)	
8977-12A	Receptacle	96				
8977-15A	Plug	177	25-19	19	# 12 (pc)	
8977-16A	Receptacle	87				
8977-17A	Plug	177	25-20	10	# 20 (pc)	
8977-18A	Receptacle	87		13	# 16 (pc)	
				4	# 12 (cc)	
			3	# 8 (cc)		
8977-19A	Plug	174	25-35	128	# 22 (sc)	
8977-20A	Receptacle	81				
8977-13A	Plug	169	25-61	61	# 20 (sc)	
8977-14A	Receptacle	77				
8977-25A	LSD-P	86		for plug		
8977-24A	LSD-R	11		for receptacle		

(pc) : power contact ; (cc) : coax contact ; (sc) : signal contact



# Circular Robotic Connectors

## Dimensions for Quick Disconnect (QD) Connector

### Receptacle

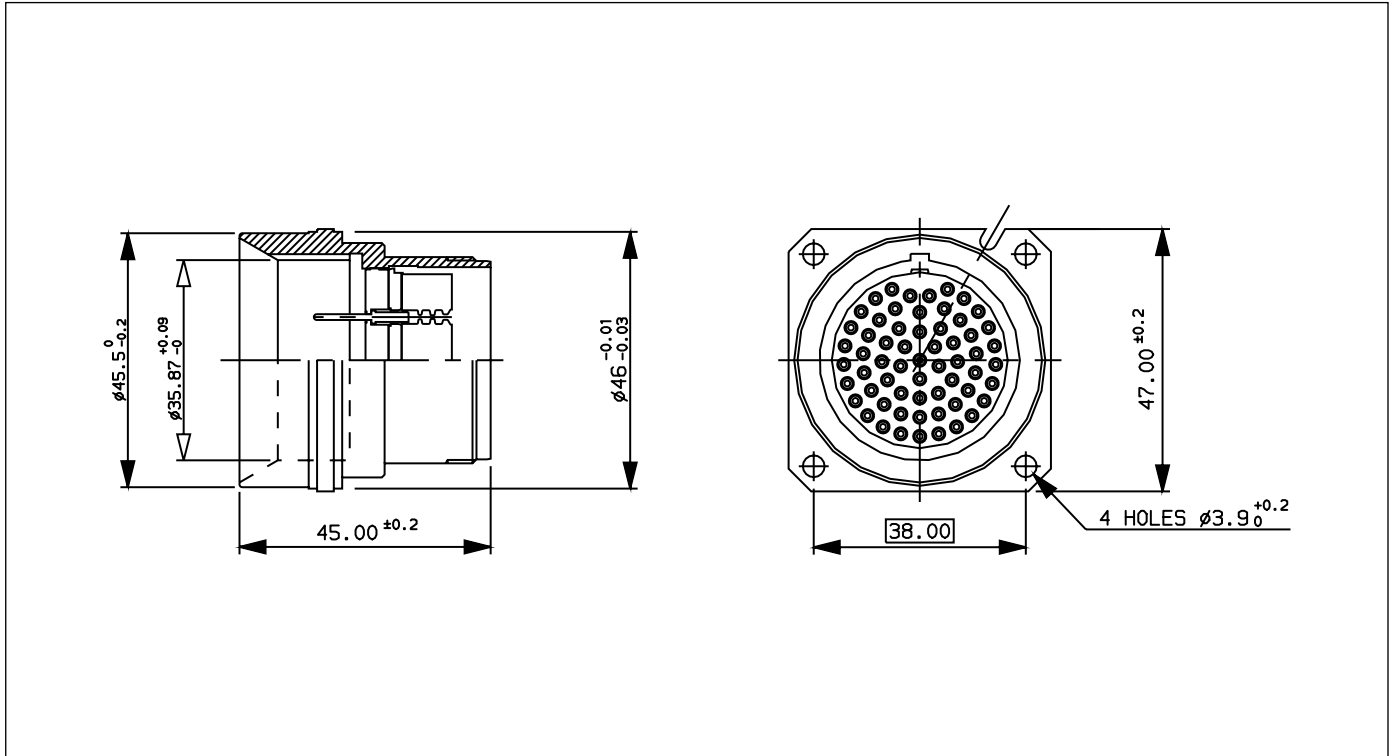

### Plug

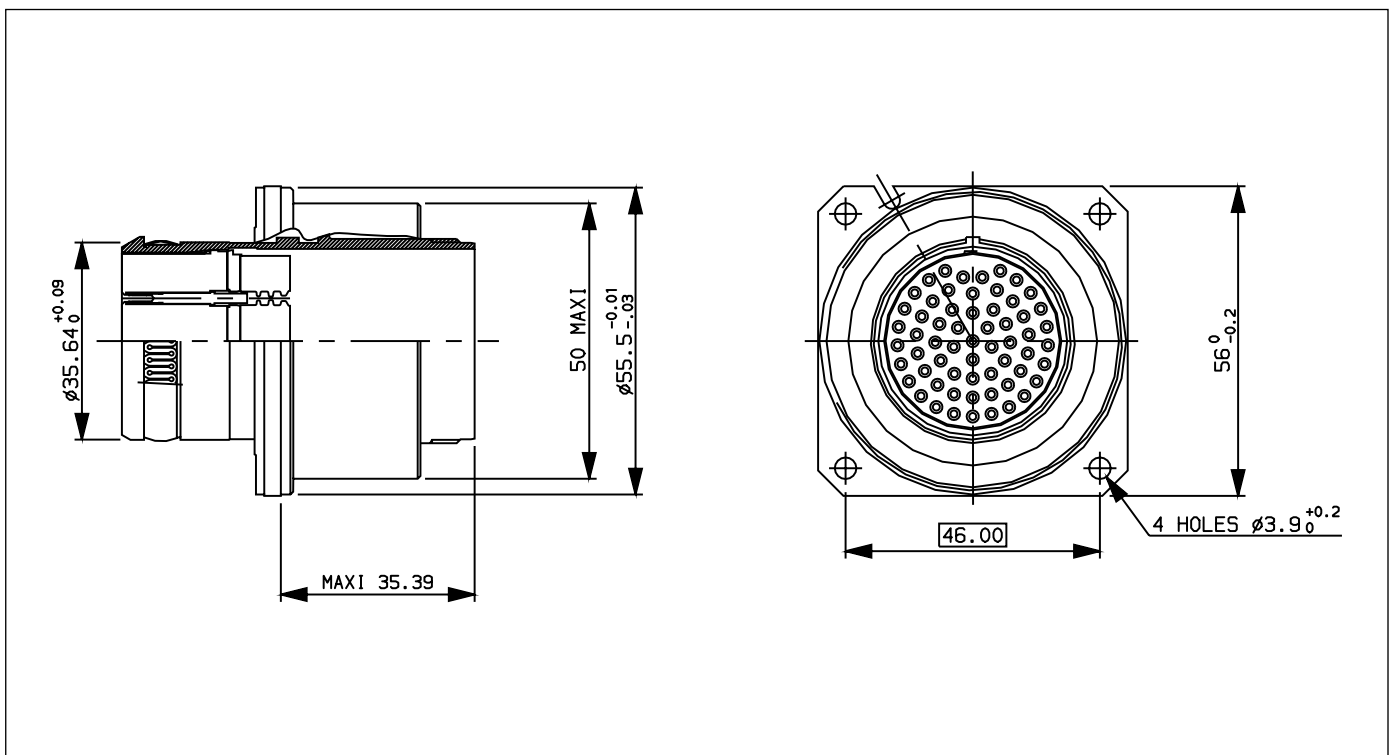



# Circular Robotic Connectors

## Dimensions for Launching Security Device (LSD)

### LSD Receptacle

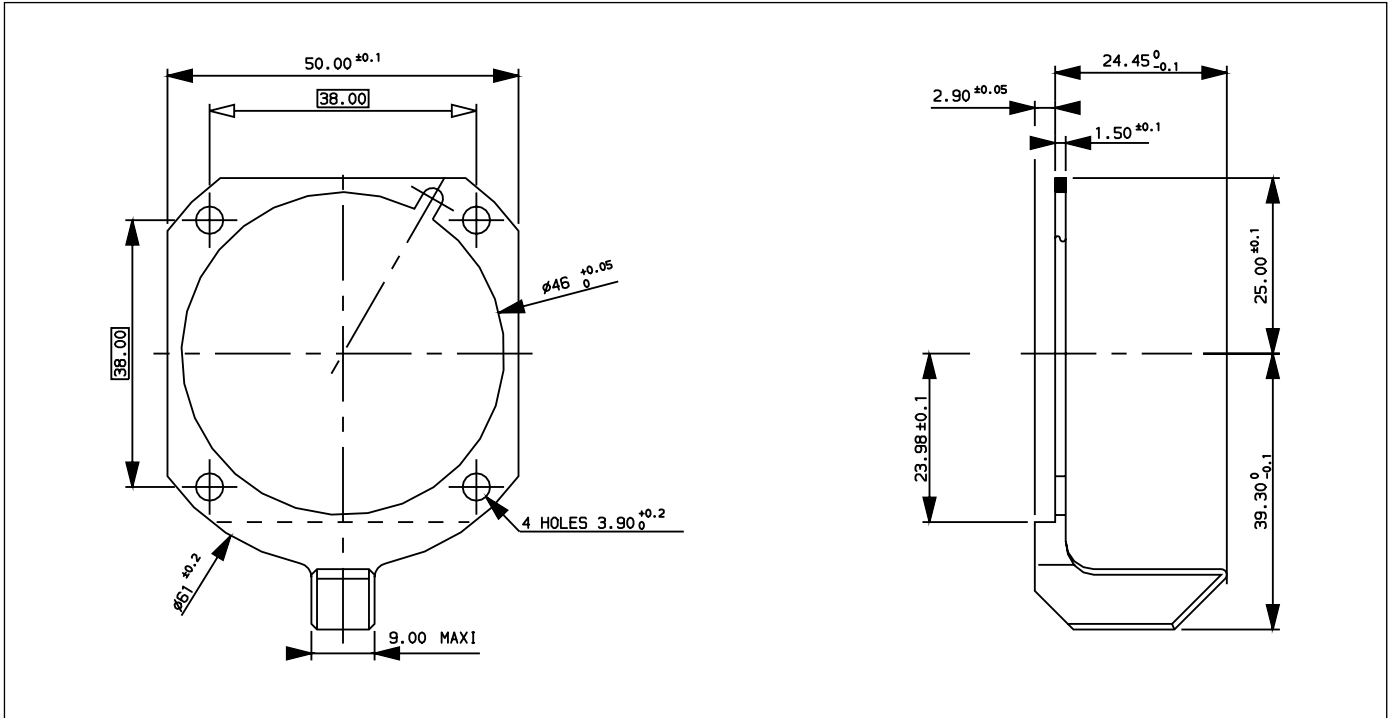

### LSD Plug

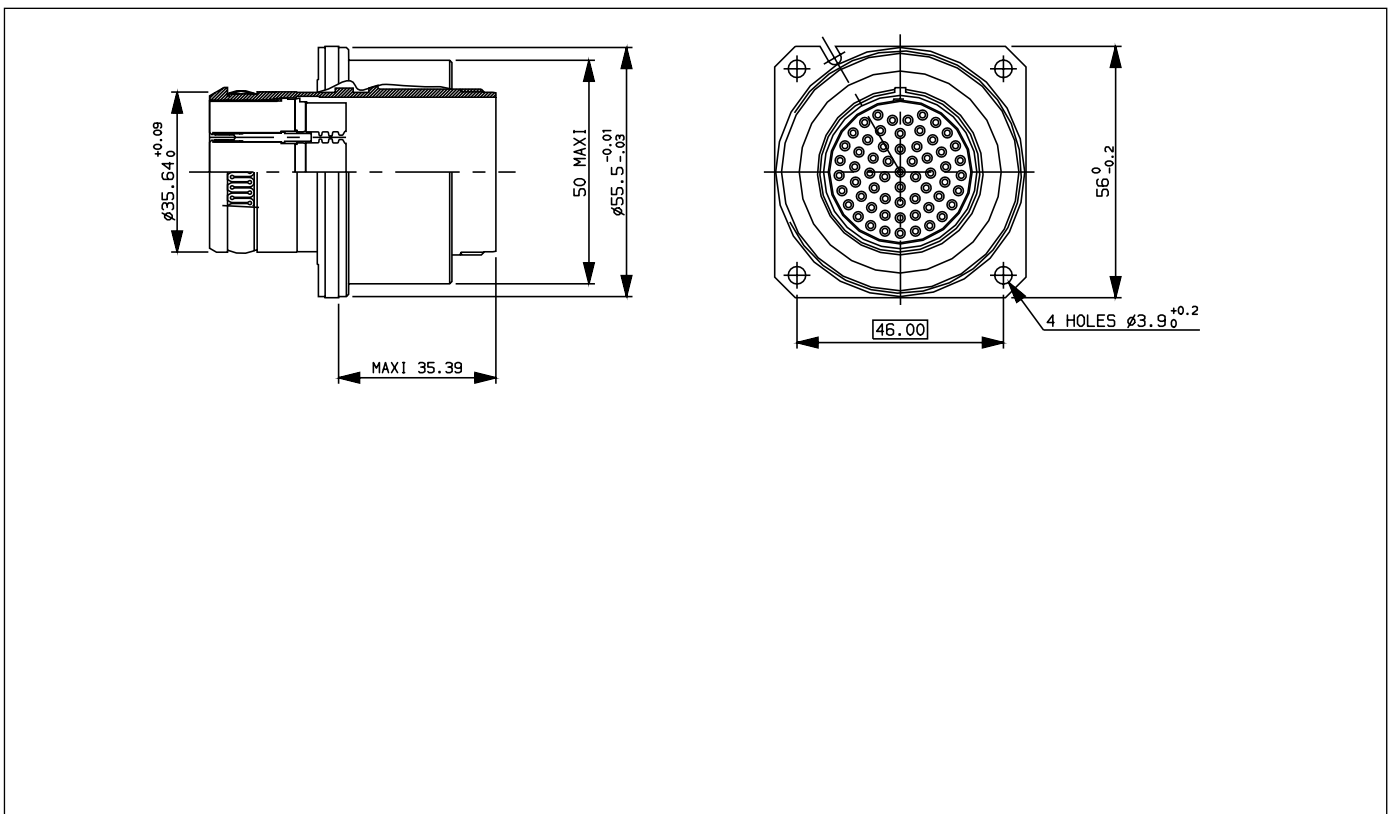

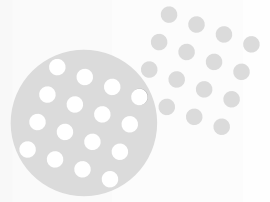

# Circular Robotic Connectors

## Presentation & Configuration for coupling

### Receptacle & Plug

#### Before mating

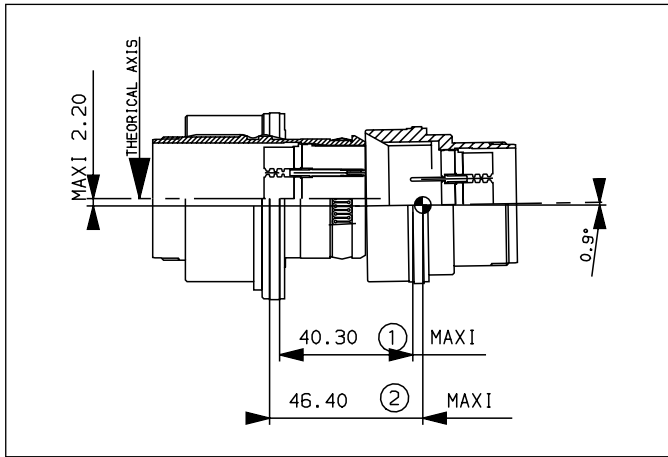

#### After mating

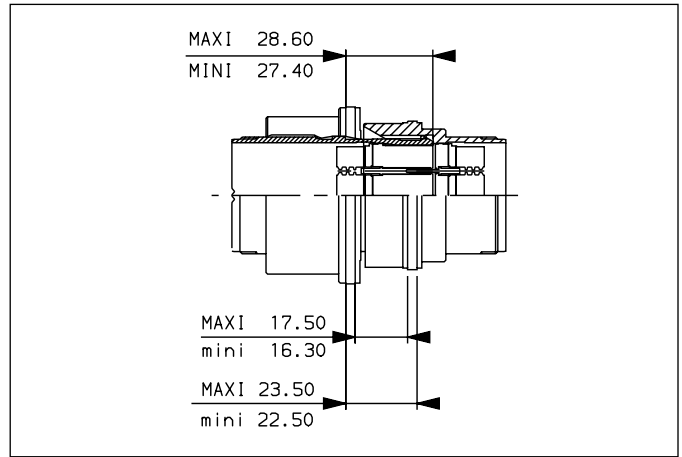

During the mating operation, the receptacle comes up to plug. The front of plug enters in receptacle cone. When plug touches the cone, this induces a lateral movement of plug shell relatively to the flange fixed on panel. This movement stops when the plug shell axis is in conformance with the receptacle ones.

The axial movement induces engagement of the plug shell key in the plug receptacle keyway, its entry cone inducing the rotation of plug shell around the X axis.

At the end of the total connection, plug comes to touch the internal face of the receptacle. The relative axial movement continues, which induces the displacement of plug shell comparatively to the flange fixed on panel. This displacement of plug shell compresses the spring in external casing.

The minimum guaranteed overstroke is 1,5 mm.

### Connector with Launching Security Device (LSD)

#### Before mating

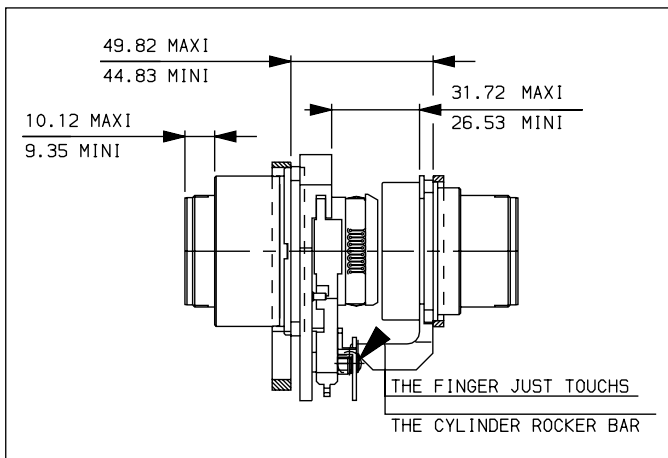

#### After mating

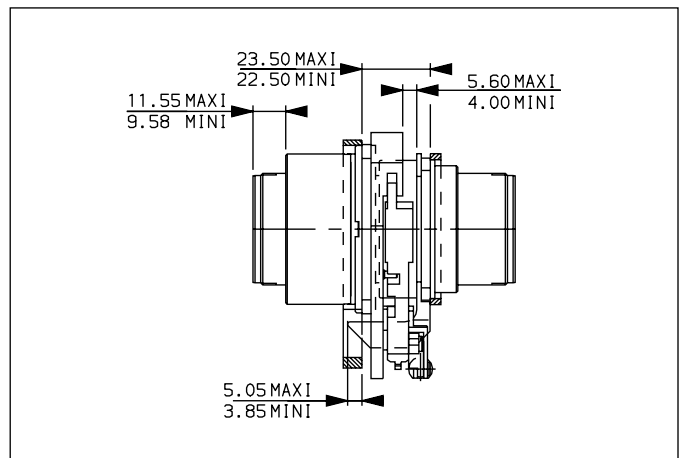

The Launching Security Device is designed to catch the floating connector plug shell during the flight.

Its two principal parts are respectively fixed with plug and receptacle flanges.

LSD side is fixed on plug flange. The plug shell is blocked by two arms and the system is locked by the cylinder rocker bar.

The LSD arms prevent plug shell movements caused by vibrations and acceleration during the launch.

When the coupling of the two parts happens, the finger of receptacle part pushes the cylinder rocker bar which releases the arms and liberates plug shell.

At this point, the mating occurs as described above.

The LSD in unlocked position will necessitate an external and manual action to be locked again on plug shell.



# Circular Robotic Connectors

## Panel cut-out

### Without Launching Security Device (LSD)

#### Plug

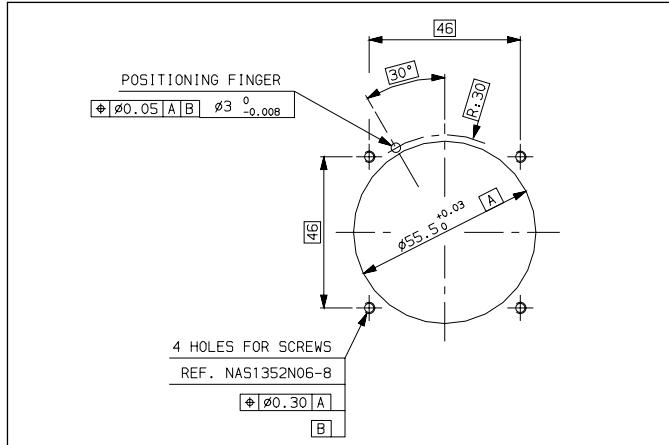

#### Receptacle

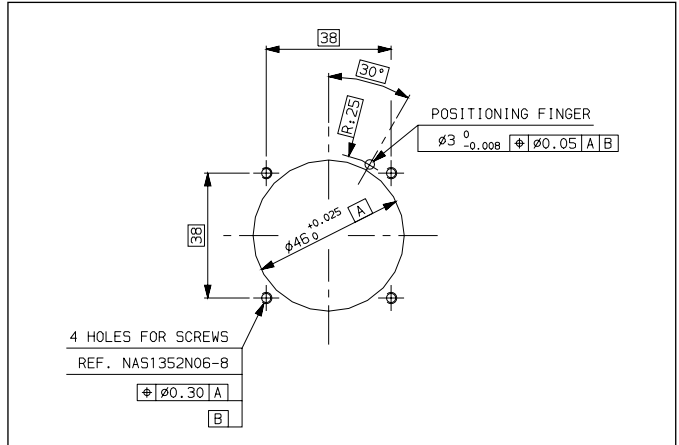

### QD connector with Launching Security Device (LSD)

#### Plug

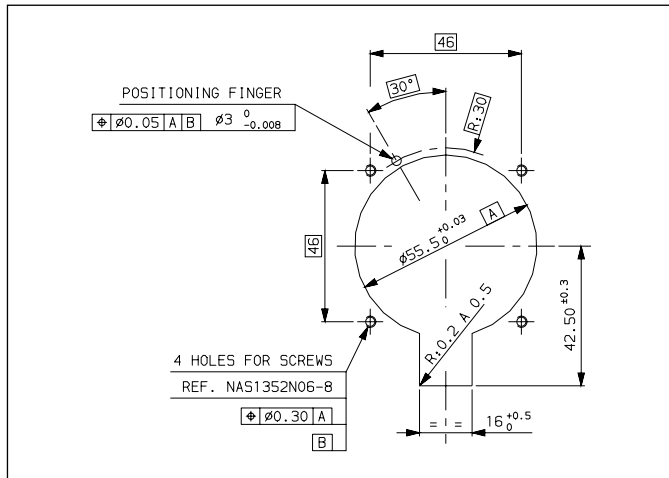

#### Receptacle

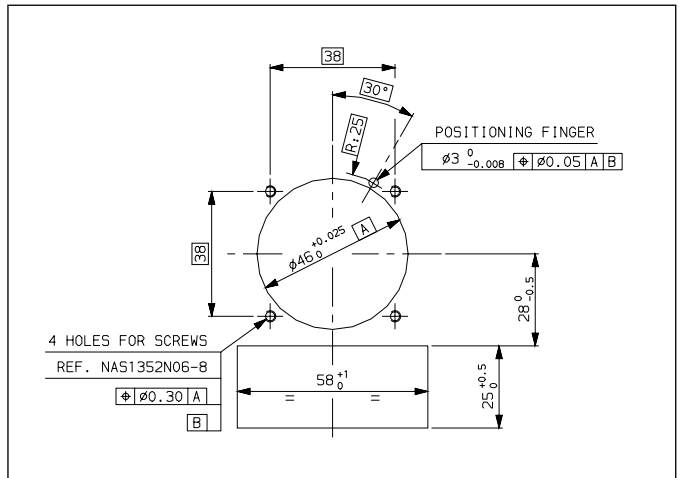

## Crimping, Insertion & Removal tools for contacts

Size contacts	Contact	Crimping tools	Positioner	Insertion & Removal plastic tools
# 22	Pin Socket	M 22520/2-01	M 22520/2-09 M 22520/2-07	M 81696/14-01
# 20	Pin Socket	M 22520/1-01	M 22520/1-04	M 81696/14-10
# 16	Pin Socket			M 81696/14-03
# 12	Pin Socket			M 81696/14-04
# 8	Pin Socket	M 22520/23-01 + M 22520/23-02	M 22520/23-09	M 81696/14-12*
# 4	Pin Socket	M 22520/23-01 + M 22520/23-04	M 22520/23-11	M 81696/14-07*
# 8 coax	Pin Socket	M 22520/1-01 + M 22520/5-01 + M 22520/5-45 (jaws)	C31-SN 1891 K103	8660-197* (1)

# Circular Robotic Connectors



## ERA Model

In the frame of Space Station Alpha program, SOURIAU has developed a series of high reliability circular connector for robotic operations. This hardware is used on ERA (European Robotic Arm) interface with ORU (Orbital Replacement Unit) and Russian Modules. These connectors feature :

- Low Insertion Force contacts
- Thermal gradient compatibility
- Integral misalignment catching system
- High durability (20.000 operations)
- High EMI shielding effectiveness
- Deep space environment (ATOX) compatibility
- Hybrid layout.



## Connecting stroke

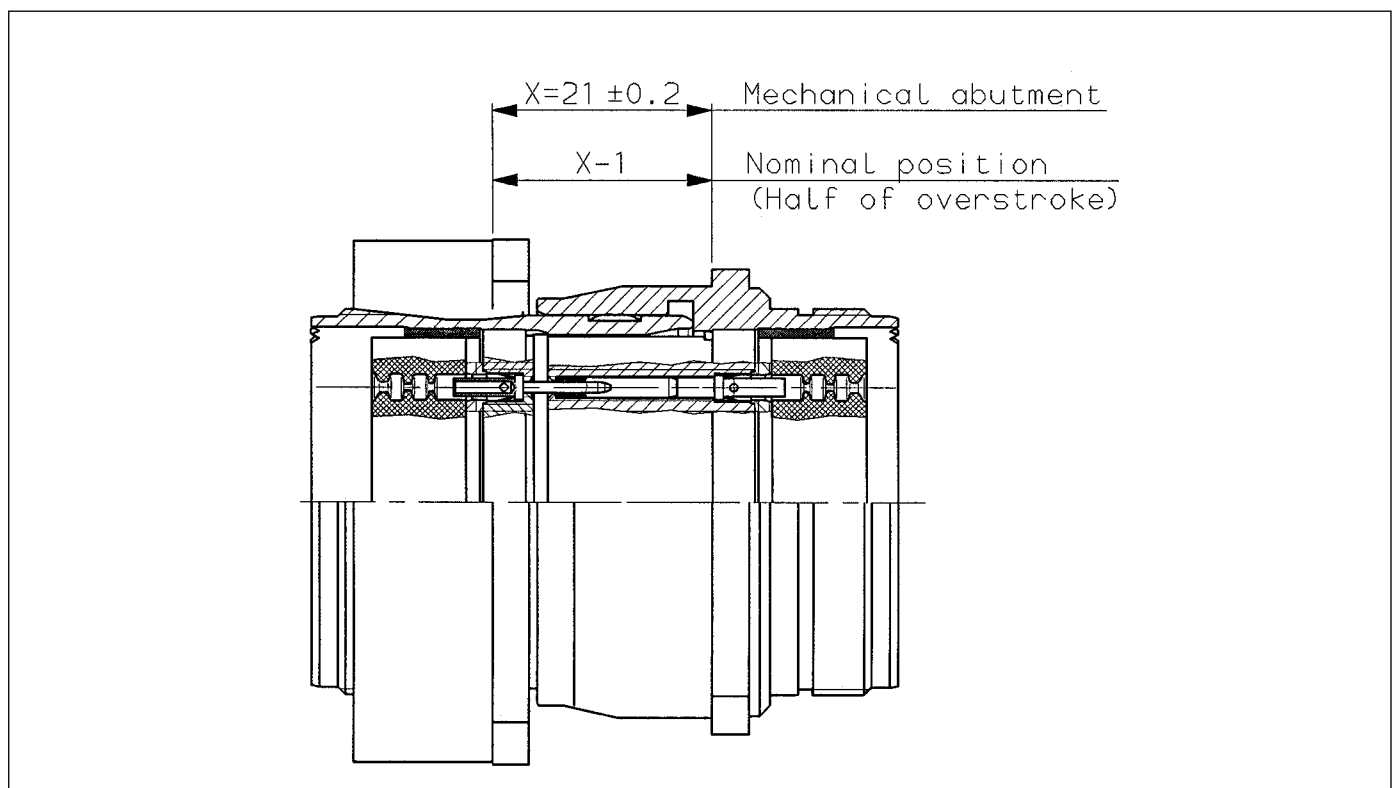



# Circular Robotic Connectors

## Dimensions (mm)

### • ERA Receptacle

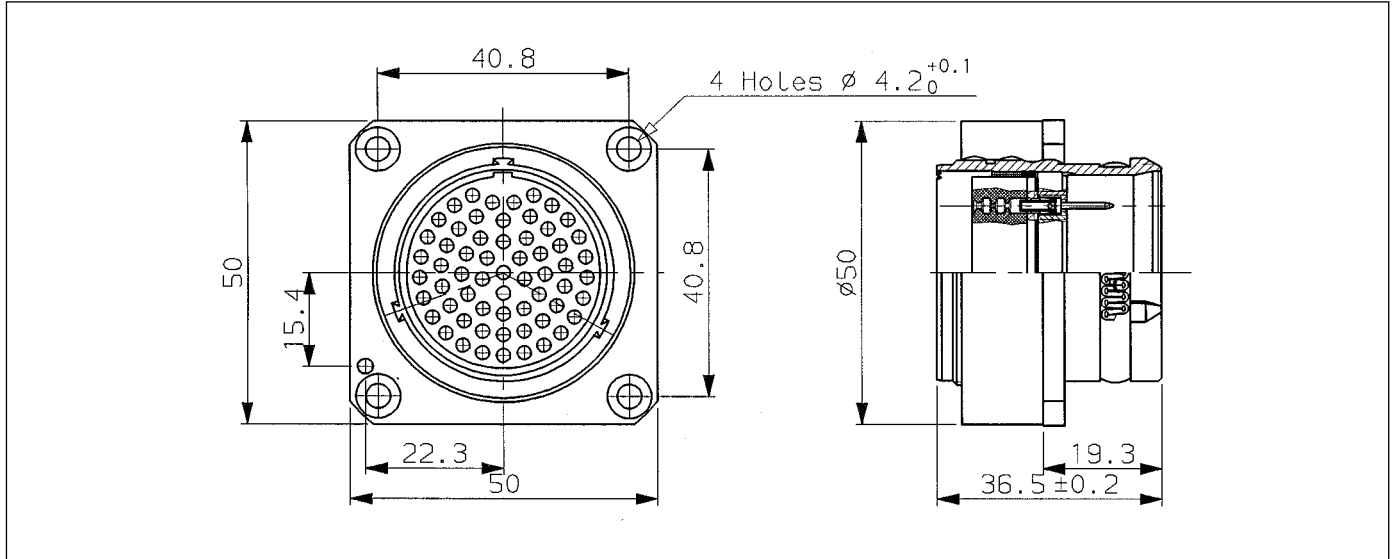

### • ERA Plug

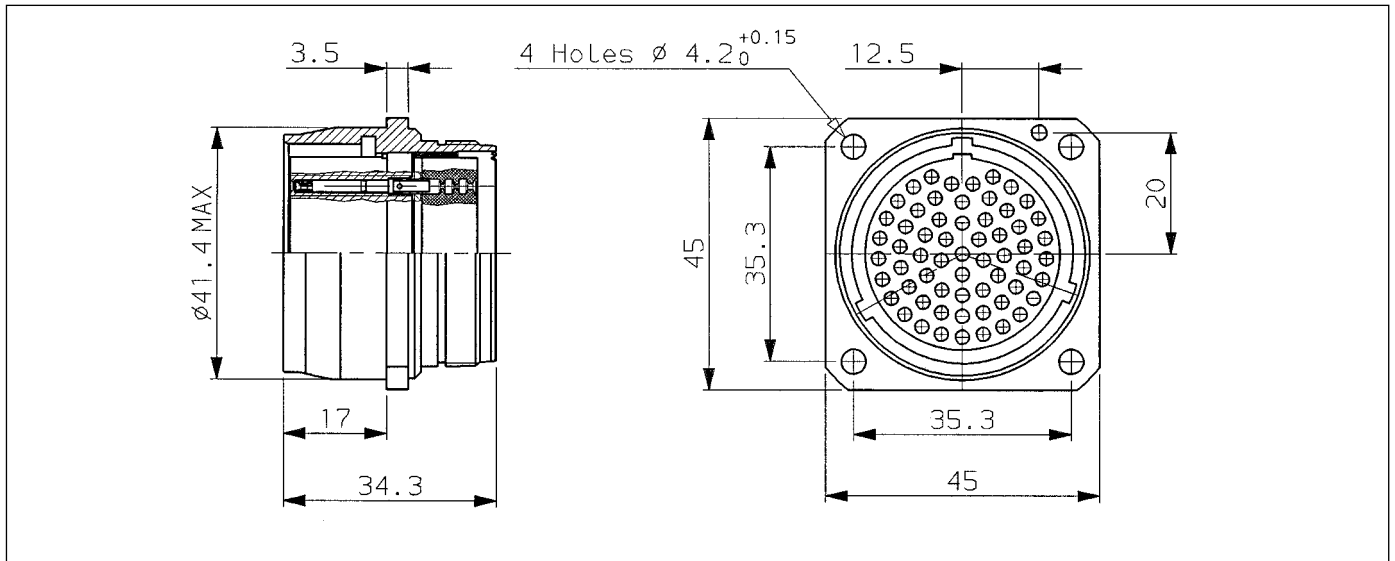

### • Layouts

